

ECONORAM IV^{T.M.} USER'S MANUAL

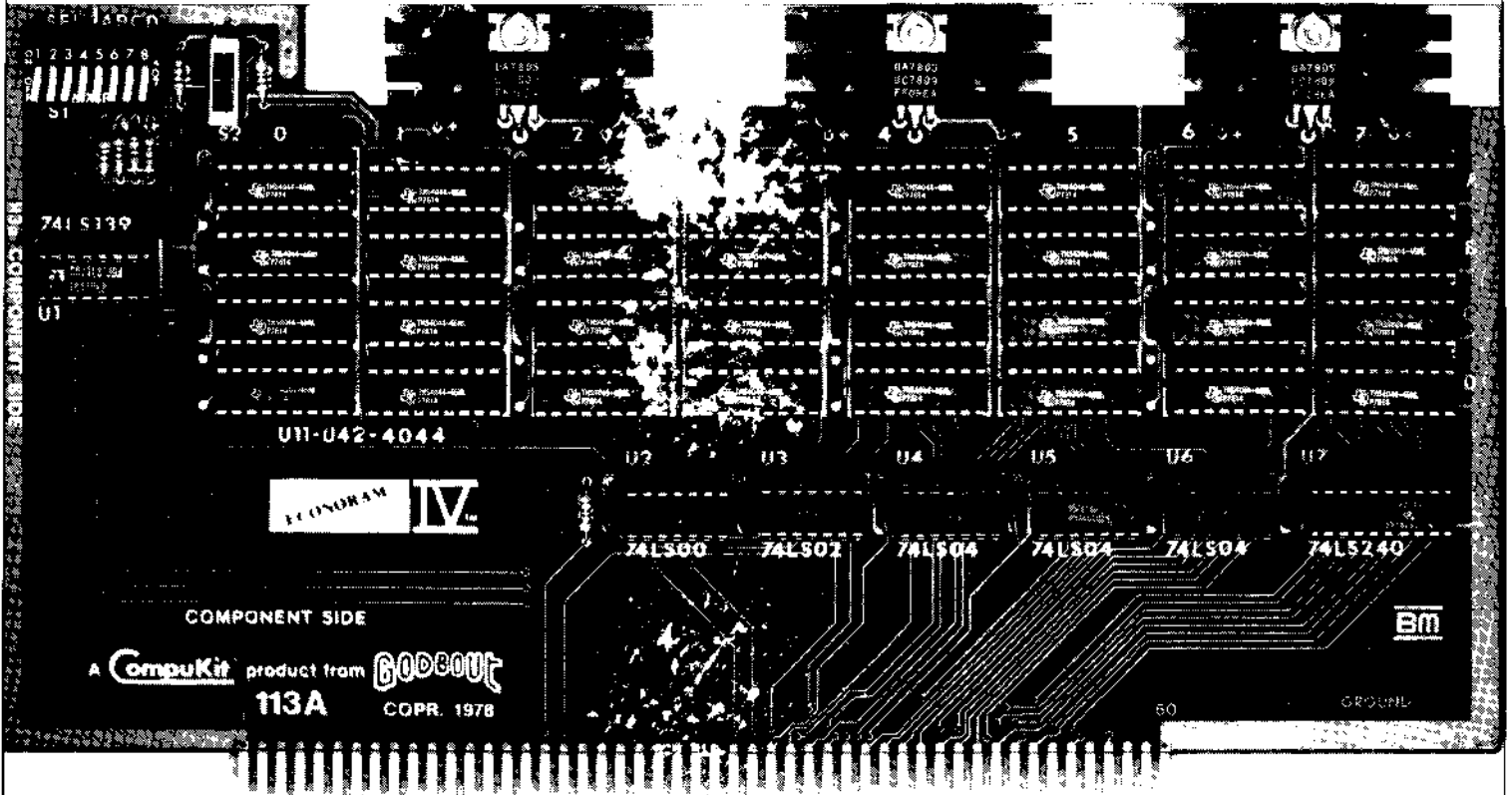

16K x 8 static memory • S-100
using TMS40L44/MM5257 • 4MHz

410489?



A **CompuKit^{T.M.}** product from **GODBOU**

Table of contents

About Econoram IV.....	3
Technical overview	3
Parts list	3
Assembly procedures	4
Component layout	5
Construction	6
Memory address assignment/disable	7
Memory protect switches.....	7
Write strobe select switch.....	7
Phantom line.....	7
Caution	7
Schematics	8, 9
Memory testing	10
Memory testing routine.....	10
Circuit description.....	11
Customer service information.....	12
Limited warranty information.....	12

Congratulations on your decision to purchase ECONORAM IV, a 16K x 8 memory board designed specifically for electrical and mechanical compatibility with the S-100 buss standard. The S-100 buss currently is one of the most popular in the industry and by far the most prolific; we believe this board, with the rest of the S-100 portion of the ECONORAM family, is one of the best memory boards available for that buss.

We recommend that the parts in this kit be checked against the parts list for completeness and that these instructions be read through carefully before starting. Completion of the assembly should take from one to four hours, depending on previous assembly experience, and upon completion, you will discover -- as thousands of satisfied ECONORAM owners have discovered -- the pleasure of using a fine memory board that just works, and works, and works.

As the first company to nationally offer memory kits to computer hobbyists, we again thank you for choosing ECONORAM IV ... welcome to the club.

This board incorporates proven static memory technology. There are currently two popular types of memory being used in products such as this: static and dynamic. Static memories are the overwhelming choice in applications where speed, complexity, ease of use, and reliability must all be considered ... there is no refresh slowdown, the CPU is freed from the drudgery of caretaking the memory, and techniques such as direct memory access (DMA) are far more reliable and easier to implement.

The individual memory ICs used on this board are grouped together to form a single 16K x 8 block of memory, addressable on any 16K boundary using the on-board dip switch (no jumpers required). Additional features include write protect switches for each 4K sector of the 16K block; a write strobe selection switch which allows use of memory in systems with or without a front panel (MWRITE strobe); allowance for use with or without the PHANTOM line; thorough capacitor bypassing of supply lines to suppress transients; plus on-board regulation and heat-sinking for reliably cool operation. All this and sockets for all ICs go onto a double-sided, solder-masked printed circuit board with a complete component-layout legend.

Parts List

Upon receipt of your kit, check your parts against the list below.

- (1) Econoram IV circuit board.

INTEGRATED CIRCUITS (note: the following parts may have letter suffixes and prefixes along with the key numbers given below.)

- (32) TMS4044 or MM5257N-3L memories (U11 - U42)
- (1) 74LS00 nand gate (U2)
- (1) 74LS02 nor gate (U3)
- (3) 74LS04 hex inverters (U4 - U6)
- (1) 74LS240 TRI-STATE* inverters (U7)
- (1) 74LS139 dual 1 of 4 decoder (U1)
- (3) 7805 positive 5V regulators (U8 - U10)

OTHER ELECTRONIC COMPONENTS

- (7) 2.7K ohm resistors (red-violet-red; R1 - R7)
- (6) 39uF tantalum capacitors (C1 - C6)
- (14) ceramic disk bypass capacitors*

MECHANICAL COMPONENTS

- (39) low profile sockets*
- (1) slide switch (S2)
- (1) 8 pole dip switch (S1)
- (3) heat sinks for regulator ICs
- (3) 6-32 bolts
- (3) 6-32 lockwashers
- (3) 6-32 nuts
- (1) instruction booklet

*supplied already soldered to board.

ASSEMBLY PROCEDURES

Proper operation of your kit depends on good soldering technique, along with correct identification and handling of the various parts used during construction. Read this manual *thoroughly* before plugging in your soldering iron.

SOLDERING TECHNIQUES. The Econoram Board is *solder-masked*. In case you are not familiar with solder-masked boards, they are similar to standard PC boards, but are screened with a solder-resistant coating. This mask is screened over the entire board, except where there are solder connections to be made; since solder does not comfortably hold to or flow over the resist, the chances of getting a bridge between tight, adjacent traces are decidedly minimized.

However, soldering a solder-masked board requires a bit of care. All soldering is performed on the *solder* side of the board; we recommend keeping all component leads straight up at all times, not bent over as with some other types of boards (see figure 1). When soldering, bring the iron tip in at an angle, against the board pad and component lead; then feed in a tiny bit of solder at opposite ends of the lead (see figure 2). This makes a good joint with no excess solder. **NOTE:** Use of any type of solder other than rosin core solder invalidates the warranty. Do not use any type of solder paste or corrosive flux under any conditions.

IDENTIFICATION OF PARTS. There are many ICs used in this kit; each one must be oriented correctly for proper operation. Most ICs have a dot near one corner that indicates pin 1 (see figure 3); sometimes this dot appears in conjunction with a deeply cut notch or circle. Other types indicate the pin 1 end of the IC by a deep notch, or a notch within a shallow circle (see figure 4). In case of doubt, place the IC in front of you so that any identifying numbers read from left to right; pin 1 is almost always in the lower left-hand corner (figure 5).

Additionally, the 6 tantalum capacitors must be correctly identified as to the (+) and (-) ends. The (+) end is the rounded end and is also identified with a (+) mark on the body (see figure 6).

HANDLING OF PARTS. All integrated circuits may be damaged by static electricity discharges; however, MOS ICs - such as the memory ICs included with your kit - are most susceptible to this problem. You can easily accumulate a static charge on your body in the thousands-of-Volts range (say, by walking across a rug on a dry day). If you then touch the pins of an IC, those thousands of Volts flow into the IC and can damage the internal structure. To prevent this from happening, leave the ICs in their protective foil until needed; then, before plugging in each IC, touch the protective foil with your finger to drain off any residual charge. Also, avoid wearing clothing that is prone to generating static electricity during construction (such as sweaters, certain types of acrylic fabrics, and so on).

Another caution concerns the mounting of resistors. These are small, somewhat fragile parts, and excessive force used while bending the leads may cause damage or crack the part. Either use a commercial lead bender (available from Godbout's and many other electronic vendors), or use needle-nose pliers to grasp the lead close to the body of the resistor and then bend the lead downward (see figure 7).

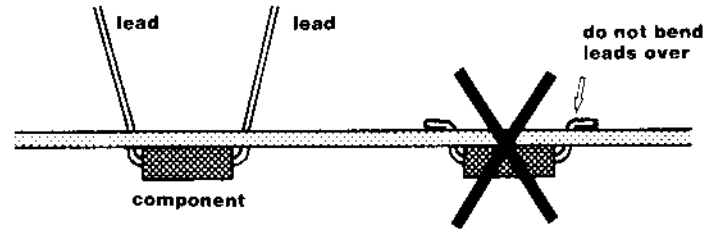

Figure 1.

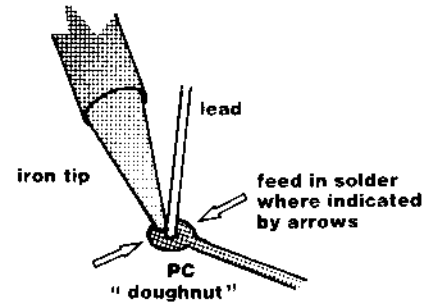

Figure 2.

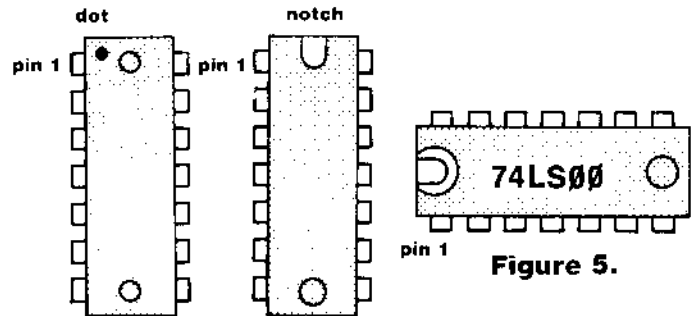

Figure 3.

Figure 4.

Figure 5.

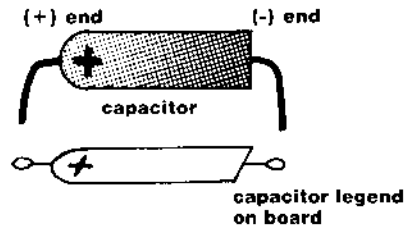

Figure 6.

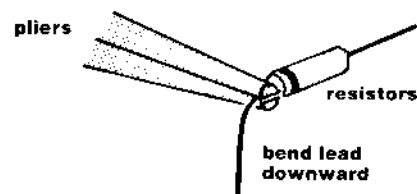
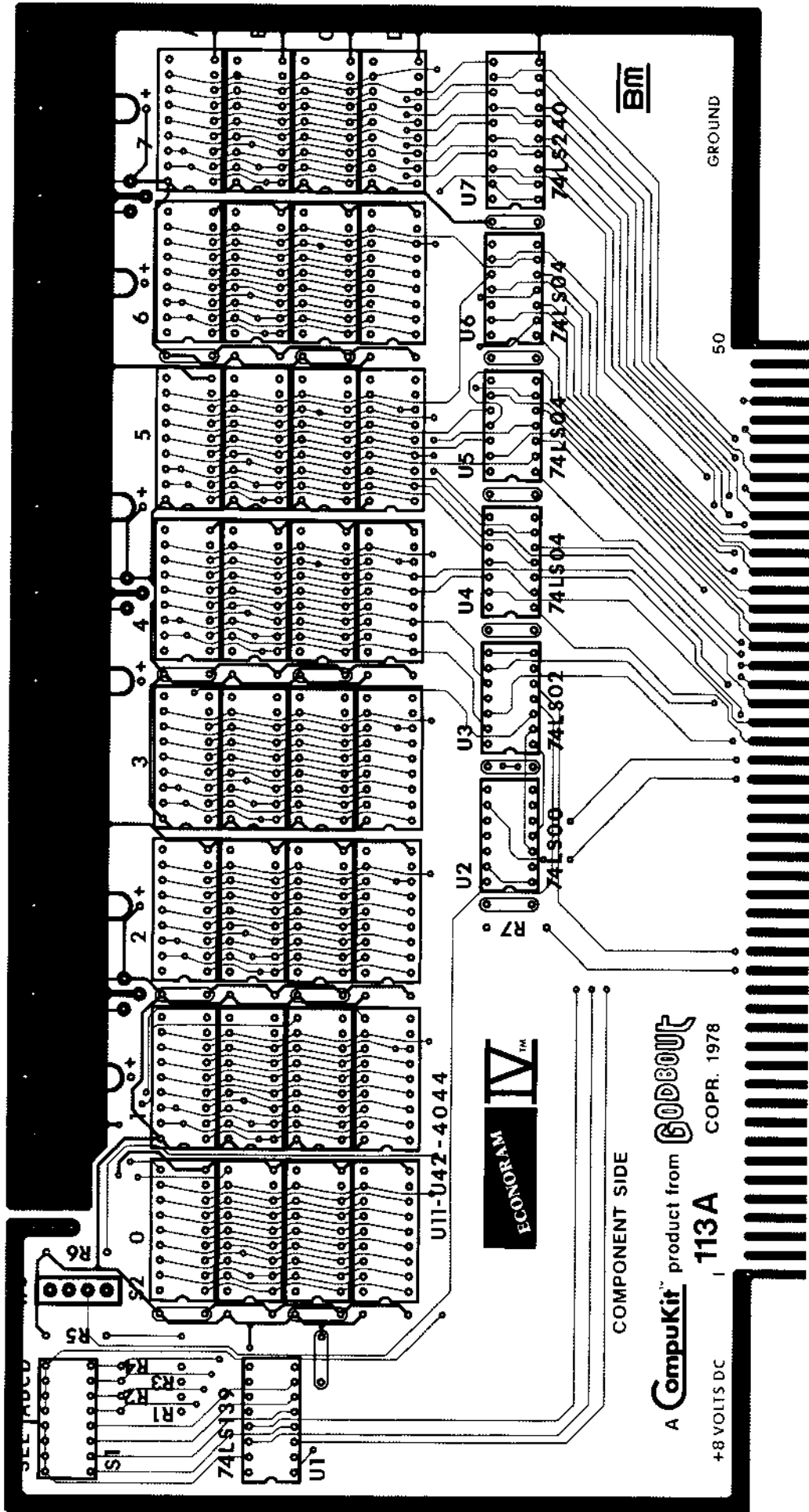

Figure 7.



Component Layout

A CompuKit™ product from **GOODBOUR**
113A COPR. 1978



CONSTRUCTION

Keeping the preceding information in mind, it is now time to mount the various components and install the ICs into their sockets. Orient the board as shown in the component layout; then referring to this layout, follow the steps below in the order given.

1. Bend leads, mount, and solder the resistors in place as indicated.
2. Bend leads, mount and solder the 6 tantalum capacitors in place as indicated, carefully observing the orientation of the (+) end.
3. Mount the slide switch in position as shown in figure 8 (note: orientation is not important).
4. Mount the three regulators and the regulator heat sinks in place. Referring to figure 9, observe that the heat sinks mount on top of the board, and then, the regulators mount on top of the heat sinks. If desired, a small dab of heat sink compound may be added between the regulator cases and heat sinks to improve thermal transfer from regulator to sink. Again referring to figure 9, bend all regulator leads as shown, then bolt the heat sink regulator assemblies into place using the provided nut, bolt, and lockwasher hardware. After these assemblies are in place, solder the regulator leads on the non-component side of the board.

5. Observe the 8 pole dip switch. The side with the number 1-8 faces the upper edge of the board (see figure 8). Mount the switch in place, and then solder. (Note: May be already soldered in place.)

6. Before proceeding, check your work so far by testing the board for any shorts between supply lines and ground. Referring to figure 10, use a Voltmeter to test for a shorted condition at the test points indicated on the regulator.

Perform this test at each regulator. If you find a short circuit at any of these points, carefully check over your board for the cause of the short. If all readings are satisfactory, proceed with construction of the board.

7. Prepare to plug in all ICs in accordance with the component layout, page 5. All ICs should have the pin 1 end facing towards the *left* side of the board; any numbers or other markings on the IC should be right side up with the board oriented as shown in the component layout. If any of the writing is upside down, the IC may not be correctly inserted.

A common problem with boards returned for repair is improper insertion of the IC; sometimes a lead from the IC will bend *under* the part instead of going into the socket contacts. We recommend inserting each IC halfway, and verifying visually that all pins are indeed going into the socket. Then, push the IC in the rest of the way.

Keeping the preceding in mind, insert the support ICs first, and then insert all memory IC.

8. Check your work over carefully for errors in construction, improperly inserted ICs, or improper polarity of the tantalum capacitors. If all is well, assembly of your board is now complete.

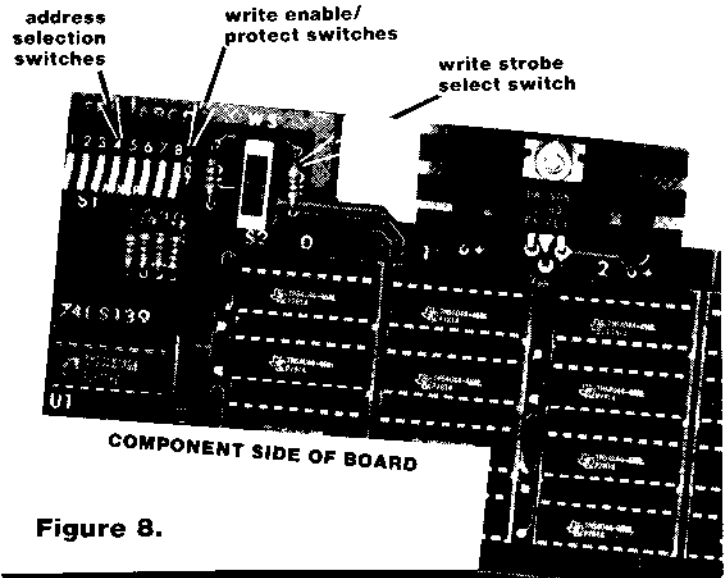

Figure 8.

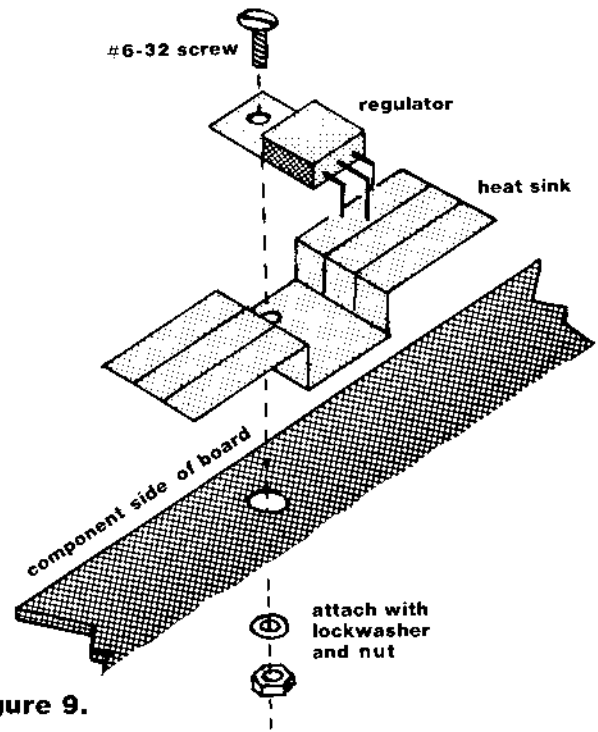

Figure 9.

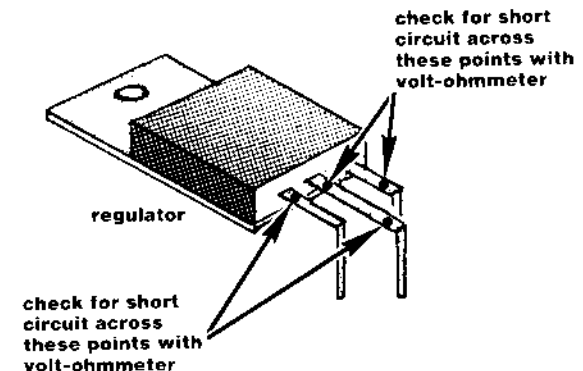

Figure 10.

MEMORY ADDRESS ASSIGNMENT

This board is addressable as a single 16K block on any 16K boundary. DIP switch positions 1-4 select which 16K area of memory the board will be associated with as follows:

- 1 - 0000 - 3FFF (hex)
- 2 - 4000 - 7FFF (hex)
- 3 - 8000 - BFFF (hex)
- 4 - C000 - FFFF (hex)

Only one of these four switches may be up (on) at a time, however, all four may be down which will deselect the board (content of the memory may neither be changed nor read) and the board is transparent to the system allowing other boards to be addressed to that area as long as it is disabled.

MEMORY PROTECT SWITCHES

DIP switch positions 5-8 are write enable switches. Inversely they may be used for manual write protection of the memory. Each enable protects 1/4 of the 16K block of memory (4K) as follows:

- 5 - 1st 4K of 16K block
- 6 - 2nd 4K of 16K block
- 7 - 3rd 4K of 16K block
- 8 - 4th 4K of 16K block

Any combination of these four switches may be up/on with up write enabling the particular 4K area and down write protecting that area.

WRITE STROBE SELECT SWITCH

This switch selects use or non-use of the S-100 buss signal MWRITE (pin 68). This signal is normally produced by a front panel and would not be available in front panel-less machines; however, some CPU boards now implement this signal. If MWRITE is present in your machine, place the slide switch in the center position. If not present, this switch should be in the up position.

PHANTOM LINE

In response to increasing numbers of users who have requested inclusion of "Phantom" line, Buss pin 67 which is often used for implementing power on jump features. This board is designed for use with active or inactive phantom lines. Boards which are revision "A" or earlier have this line solidly connected. Revision "B" and later boards require a jumper to implement this feature (see figure 11).

CAUTION

Some manufacturers use the PHANTOM line (buss pin 67) for a refresh signal. This will conflict with the PHANTOM feature, and cause boards with PHANTOM to fail. If your system has this conflict it must be resolved by either eliminating the refresh signal on the CPU board or disabling the PHANTOM feature on this and other boards.

On revision "A" or earlier boards the Phantom feature may be disabled by cutting the trace where it leaves buss pin 67. On revision "B" and later boards the PHANTOM feature is disabled if the jumper is NOT CONNECTED on the trace to buss pin 67 (see figure 11).

If you want the PHANTOM feature, the conflicting refresh signal may be eliminated (IF NOT USED ELSEWHERE IN THE SYSTEM) by cutting the trace connected to buss pin 67 on the CPU board. BE SURE OF YOUR SYSTEM CONFIGURATION BEFORE CUTTING ANY TRACES.

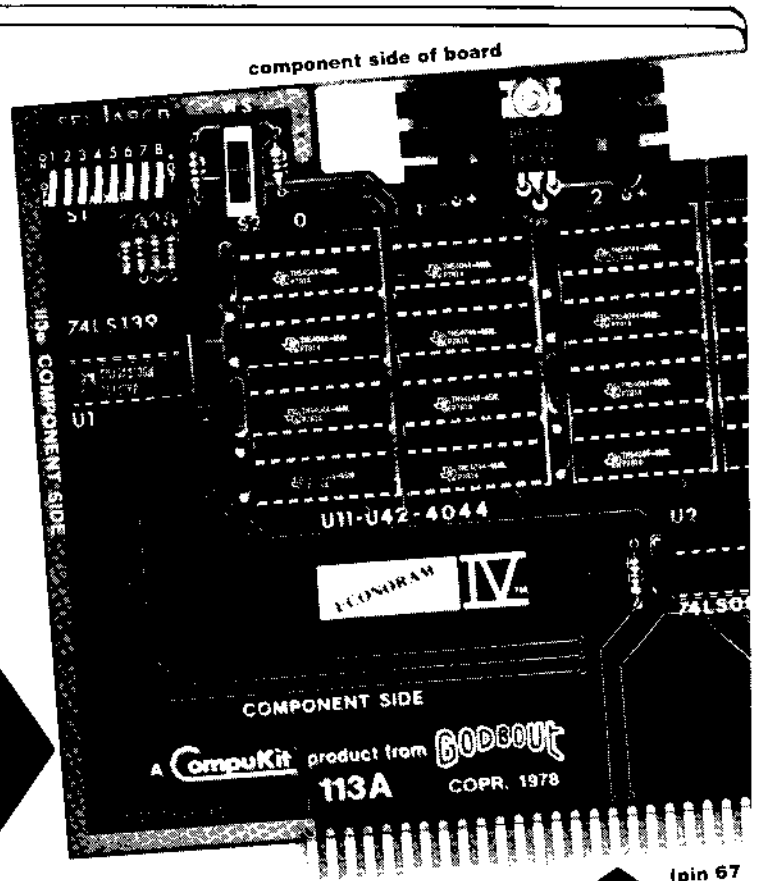
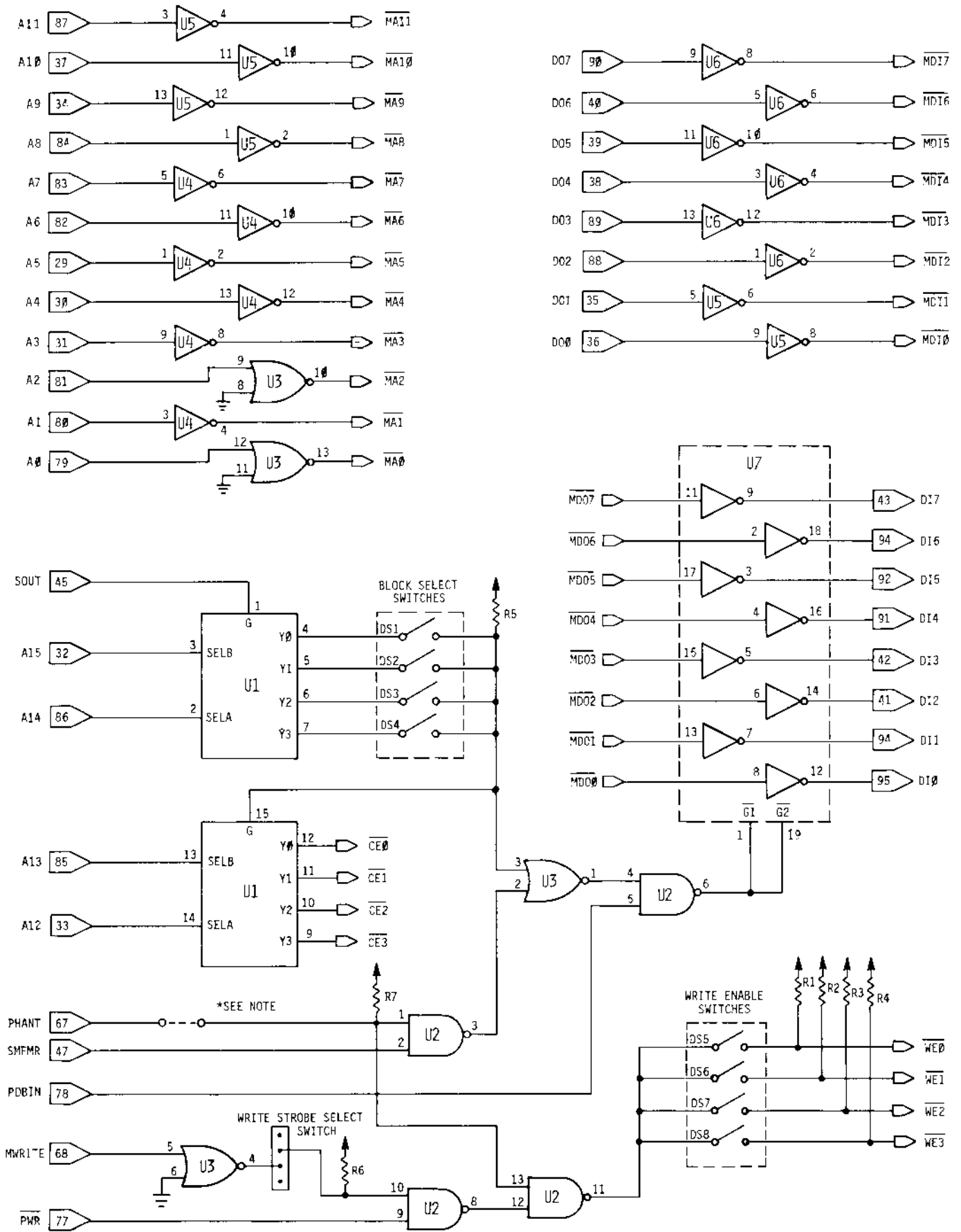
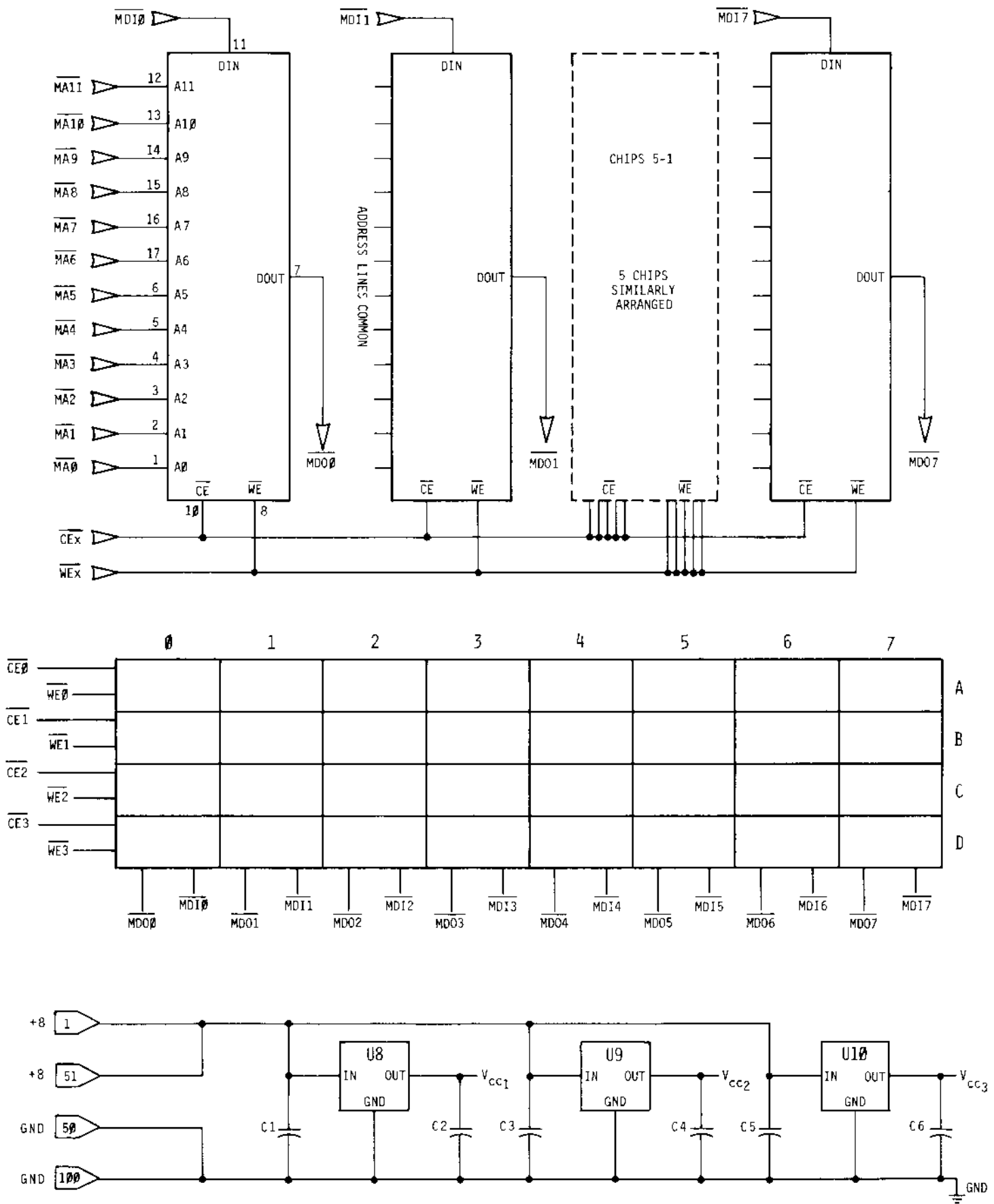

Figure 11.

SCHEMATIC - ECONORAM IV



NOTE: On revision "A" boards this trace is solid; on revision "B" and later boards require a jumper to implement.



SCHEMATIC - ECONORAM IV

MEMORY TESTING

If the memory board seems to be working properly, the Memory Testing Routine (figure 13) can be used to give the board a more thorough workout. It is rather slow; but will do the job well. It can be entered via editor/assembler or front panel switches.

The routine is set up to test 16K from 4000 hex up to 8000 hex. This may be changed by entering a different starting address at "STRT" (3001 - 3002) and/or a different end address at "END" (3004 - high order byte only).

If the memory passes the test it starts over again. You may on the other hand, insert a jump instruction at "MARK" to some user routine or, if desired the user may enter an output instruction or, can do a notification routine at "MARK" to show successful completion and restart.

If the memory fails the test, critical information is stored and the routine enters a software "HALT", that is a "jump to here" at "SHLT". Front panel lights, if any, will show this state. The user may then use the front panel or dump routines to display the following stored failure info:

- 3069* "FDE" = D, E pair ... D is the fill character and E is the test character
 - 306B* "FHL" = H, L pair ... the failure address
 - 306D* "FOUT" = the data expected at this address
 - 306E* "FIN" = the data read from, the address
- * address from *Memory Testing Routine Listing*.

The user may replace the "jump" at "SHLT" with a jump to a display or notification routine.

The difference between "FOUT" and "FIN" should indicate which bit is failing, indicating which chip or area is causing the problem.

This test will find most of the harder to distinguish errors.

MEMORY TESTING ROUTINE

```

3000 21 00 40      0010 STRT LXI  H,4000H
3003 3E 80      0020 END  MVI  A,80H
3005 32 6E 30    0030 STA  FIN
3008 3E 10      0040 MVI  A,10H
300A 84          0050 ADD  H
300B 4F          0060 MOV  C,A
300C 16 00      0070 MVI  D,0
300E 1E FF/     0080 MVI  E,0FFH
-3010 22 65 30   0090 DONE SHLD STAD
3013 AF          0100 XRA  A
3014 47          0110 MOV  B,A
3015 7B          0120 SCND MOV  A,E
3016 5A          0130 MOV  E,D
3017 57          0140 MOV  D,A
3018 79          0150 MOV  A,C
3019 2A 65 30   0160 LHL  STAD
301C 72          0170 FILL MOV  M,D
301D 23          0180 INX  H
301E BC          0190 CMP  H
301F C2 1C 30   0200 JNZ  FILL
3022 2A 65 30   0210 LHL  STAD
3025 73          0220 NEXT MOV  M,E
3026 7B          0230 MOV  A,E
3027 BE          0240 CMP  M
3028 C2 6F 30   0250 JNZ  FAIL
302B 79          0260 MOV  A,C
302C 23          0270 INX  H
302D 94          0280 SUB  H
302E C2 4D 30   0290 JNZ  NDN
3031 B8          0300 CMP  B
3032 44          0310 MOV  B,H
3033 CA 15 30   0320 JZ   SCND
3036 3A 66 30   0325 LDA  STAD+1
3039 00          0330 MARK NOP
303A 00          0331 NOP
303B 00          0332 NOP
303C 3A 6E 30   0340 LDA  FIN
303F B9/        0350 CMP  C
3040 CA 00 30   0360 JZ   STRT
3043 79/        0370 MOV  A,C
3044 67          0380 MOV  H,A
3045 2E 00      0390 MVI  L,0
3047 C6 10      0400 ADI  10H
3049 4F          0410 MOV  C,A
304A C3 10 30   0420 JMP  DONE
304D 22 67 30/  0430 NDN  SHLD NXAD
3050 7A/        0440 LOPB MOV  A,D
3051 BE          0450 LOPA CMP  M
3052 C2 6F 30   0460 JNZ  FAIL
3055 2C          0470 INR  L
3056 C2 51 30   0480 JNZ  LOPA
3059 79          0490 MOV  A,C
305A 24          0500 INR  H
305B BC          0510 CMP  H
305C C2 50 30   0520 JNZ  LOPB
305F 2A 67 30   0530 LHL  NXAD
3062 C3 25 30   0540 JMP  NEXT
3065             0550 STAD DS  2
3067             0560 NXAD DS  2
3069             0570 FDE  DS  2
306B             0580 FHL  DS  2
306D             0590 FOUT DS  1
306E             0600 FIN  DS  1
306F 22 6B 30   0610 FAIL SHLD FHL
3072 32 6D 30   0620 STA  FOUT
3075 7E          0630 MOV  A,M
3076 32 6E 30   0640 STA  FIN
3079 EB          0650 XCHG
307A 22 69 30   0660 SHLD FDE
307D C3 7D 30   0670 SHLT JMP SHLT
3080             0680 *
    
```

~~MVI A, 'P'~~ 3E 50
MVI A, 'A' 47
MOV B, A
JMP 0083
~~POP B~~

Does 1000 H/A a time

Restore NOPS (3039-303B)

3040 should be
CA 80 30

0083 CD 79 C0
C3 24 C0
π
00 30

CIRCUIT DESCRIPTION

The heart of Econoram IV is the TMS4044/MM5257 static memory IC (RAM), which can store 4096 single bits of information (thus, each is a "4K x 1" memory IC). Unlike standard RAMs, those included with your kit are specifically designed by the manufacturer as low power, high speed parts.

These ICs are arranged in rows that are 8 ICs wide. This way, each row can store 4K x 8 bits of information. Paralleling 4 of these rows together produces a total memory storage of 16K x 8 bits. (Note that the bit number corresponding to a given column of ICs is indicated along the top edge of the memory array).

Now that we have this storage, there are still other aspects we must consider. First, we need to address a specific location in memory; and, we need to be able to *write* data into the memory, or *read* data from the memory.

The schematics on pages 8 and 9 show the address circuitry along with the other Econoram IV circuitry. Each memory IC requires 12 address bits (A0-A11) to access any one of the 4096 bits available in the IC. These address bits are generated by the CPU and are buffered by a number of inverters. After buffering, a particular address is presented to all IC address selection pins. However, we additionally need to select which particular row of ICs is to react to the given address. This requires 4 more address bits (A12-A15), which are decoded and used to enable the desired row of ICs (note row markings along the right hand side of the memory array).

When data is to be written into memory, it first passes through 8 inverting buffers before being put on the data pins of the RAMs (buffering prevents loading of the data buss). Data to be read on to the data buss from memory passes through 8 TRI-STATE[®] inverting buss drivers; when data is not being read on to the buss, the outputs of these inverters are in a high-impedance or "disconnected" state.

An unfortunate fact of life is that logic ICs generate switching transients that travel along the power supply lines. If these transients work their way into the logic circuitry, problems can appear. To prevent such occurrences, bypass capacitors are tied across the power lines at regular intervals in the memory array and at every support IC.

This board is guaranteed to operate at 4MHz over the full temperature range (0° - 70° C ambient) and to draw less than 2000 mA (2 amps). Our typical measured currents were less than 1600 mA at cold start-up, rapidly decreasing to around 1200-1400 mA, depending on the surrounding temperature. We have heard similar reports from the people already using these boards.

It is interesting to note that static RAM technology has progressed to the point that this high-performance static RAM board is comparable in cost and power consumption to dynamic memory boards.

THANK YOU

This board is the result of much time, work and experience on the part of a number of people.

We strive for a board that doesn't just work the first time, but continues to give reliable operation for a long time. If we can be of any help to you in applying this board, or if you have any questions, please let us know. As always, we solicit your comments, letters, and new product suggestions.

HAPPY COMPUTING!

CUSTOMER SERVICE INFORMATION

Our paramount concern is that you be satisfied with any Godbout CompuKit product. If this product fails to operate properly, it may be returned to us, see warranty information below.

If you have any questions about assembly, performance, specifications or need further information feel free to write us at:

P.O. Box 2355, Oakland Airport, CA 94614.

When writing, please be as specific as possible concerning the nature of your query. We maintain a 24 hour a day phone, for taking orders, (415) 562-0636. If you have problems or questions which cannot be handled by mail, this number can be used to connect you with our technical people ONLY during normal business hours (10am-5pm Pacific Time). Unfortunately, we cannot return calls, or accept collect calls.

LIMITED WARRANTY INFORMATION

Godbout Electronics will repair or replace, at our option, any parts found to be defective in either materials or workmanship for a period of 1 year from date of invoice. Defective parts *must* be returned for replacement.

If a defective part or design error causes a Godbout Electronics product to operate improperly during the 1 year warranty period, we will service it free (original owner only) if delivered and shipped at owner's expense to Godbout Electronics. If improper operation is due to an error or errors on the part of the purchaser, there may be a repair charge. Purchaser will be notified if this charge exceeds \$10.00.

We are not responsible for damage caused by use of solder intended for purposes other than electronic equipment construction, failure to follow printed instructions, misuse or abuse, unauthorized modifications, use of our products in applications other than those intended by Godbout Electronics, theft, fire, or accidents.

Return to purchaser of a fully functioning unit meeting all advertised specifications in effect as of date of purchase is considered to be complete fulfillment of all warranty obligations assumed by Godbout Electronics. This warranty covers only products marketed by Godbout Electronics and does not cover other equipment used in conjunction with said products. We are not responsible for incidental or consequential damages.

Prices and specifications are subject to change without notice, owing to the volatile nature and pricing structure of the electronics industry.

"Econoram" and "Econoram IV" are trademarks of W.J. Godbout.

TRI-STATE® is a trademark of National Semiconductor Corp.

Contents of this booklet ©1979 by Godbout Electronics. All rights reserved. We encourage quotation for the purposes of product review if source is credited.